

REV.	ECO/PCN/DESCRIPTION	BY	CHK	APP.	DATE
A	RELEASE FOR REFERENCE	DC			09/27/10

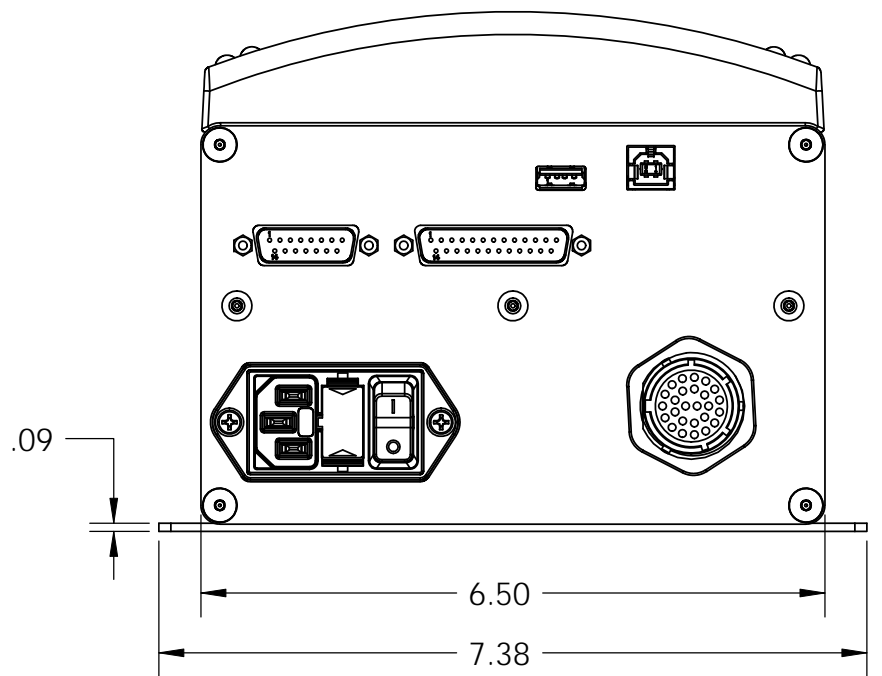
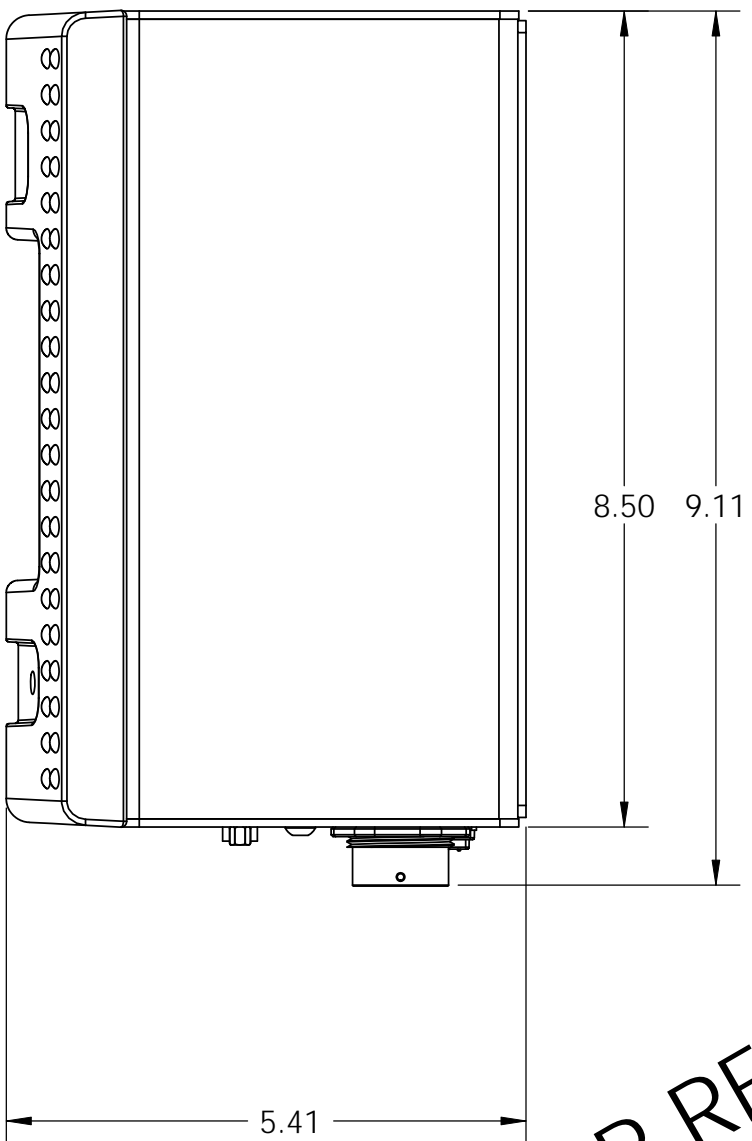
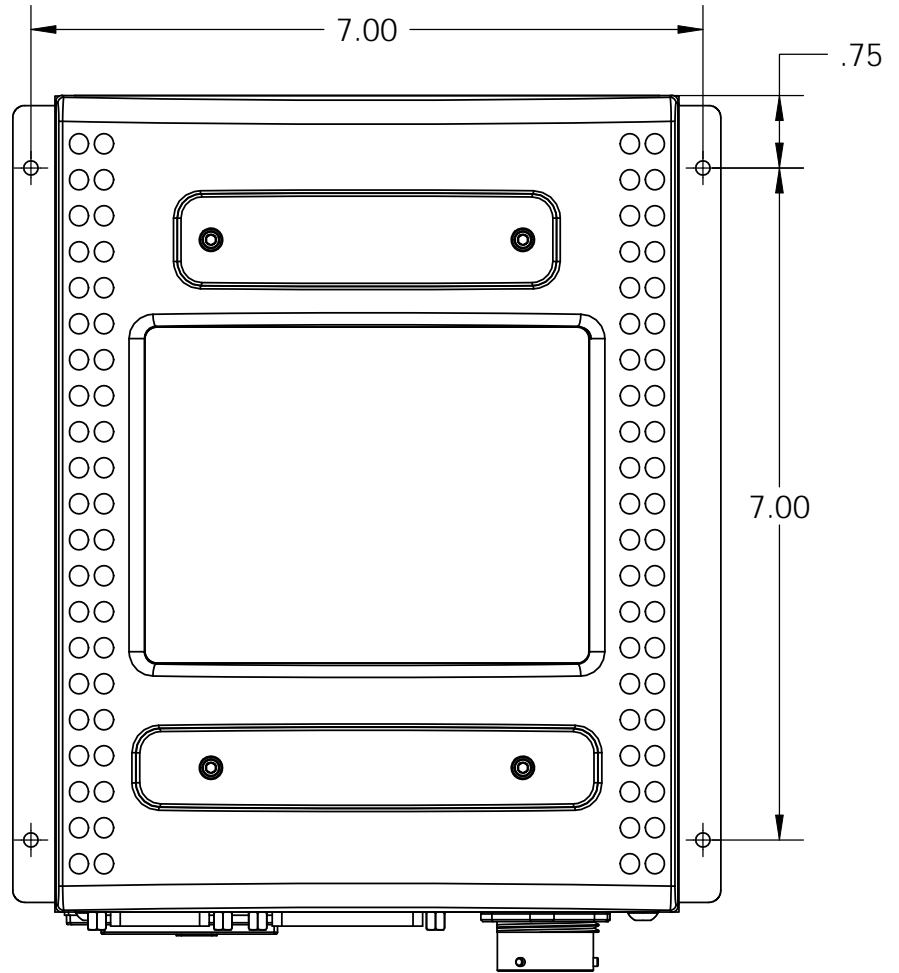

FOR REFERENCE ONLY

DO NOT SCALE THIS PRINT
LIMITS UNLESS OTHERWISE SPECIFIED

.000 ± .005
.00 ± .01

FRACTION ± 1/64
ANGLES ± 1/2 DEG
FINISHES 125 MAX

REMOVE ALL BURRS AND
BREAK SHARP EDGES .005/.010

INSIDE CORNERS .035 R MAX

DIMENSIONS ARE IN INCHES

SERIES:

THIRD ANGLE PROJECTION



TITLE		SD2500 CONTROLLER	
SAP DESCR.			
CAD FILE	SOLIDWORKS	DWN.	DC
CAD FILE LOC.		CHK.	
SCALE	1:4	APPD.	
DATE	09/27/10	DATE	
SIZE	B	DWG. NO.	ASG-SD2500
SHEET	1 of 1	REV.	A

CONFIDENTIAL

RELEASED TO AND ACCEPTED BY THE POSSESSOR ON CONDITION
THAT NO RIGHTS OF REPRODUCTION OR USE ARE GIVEN
EXCEPT FOR PURPOSE ELSEWHERE SPECIFIED IN WRITING BY MICROROTQ LLC.