

8 7 6 5 4 3 2 1

REV.	ECN/PCN/DESCRIPTION	BY	DATE

D
C
B
A

D
C
B
A

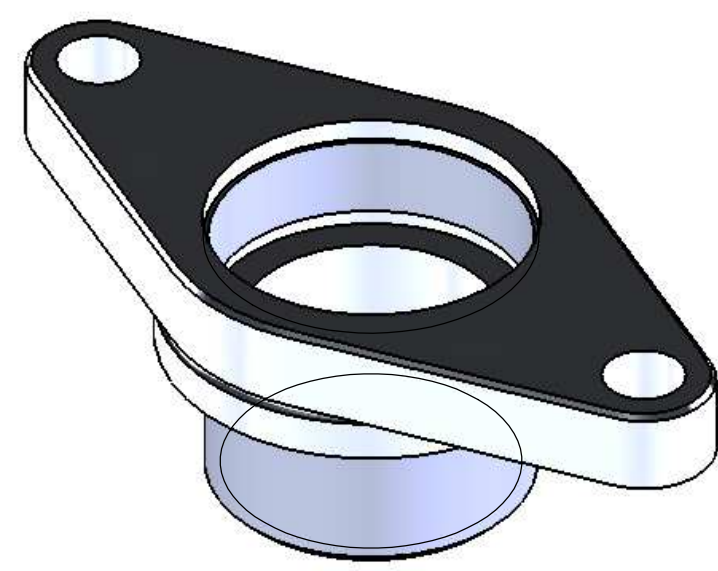
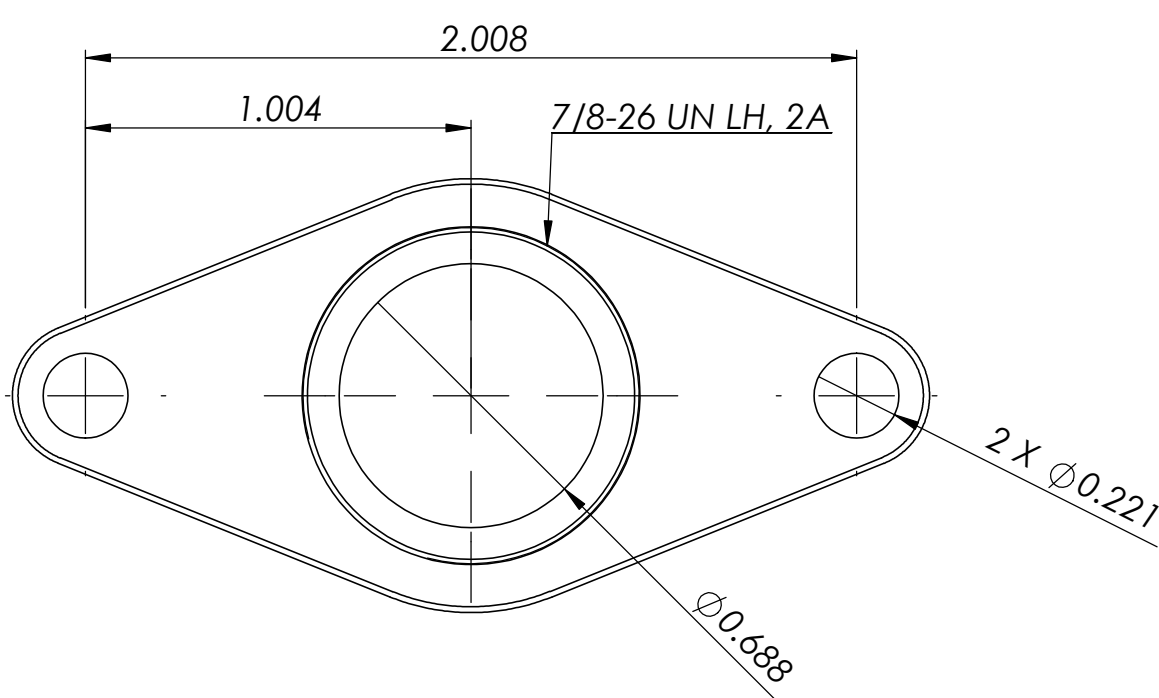
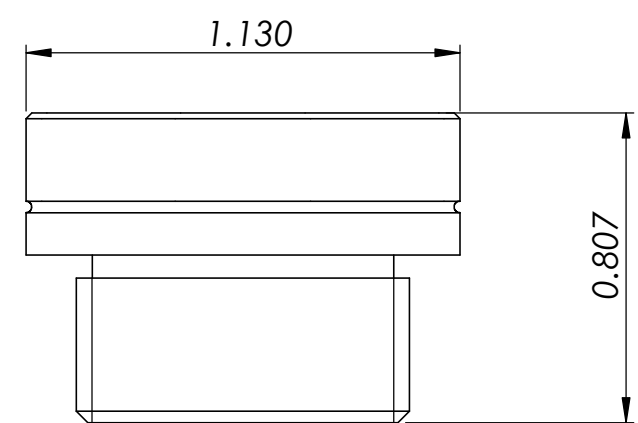
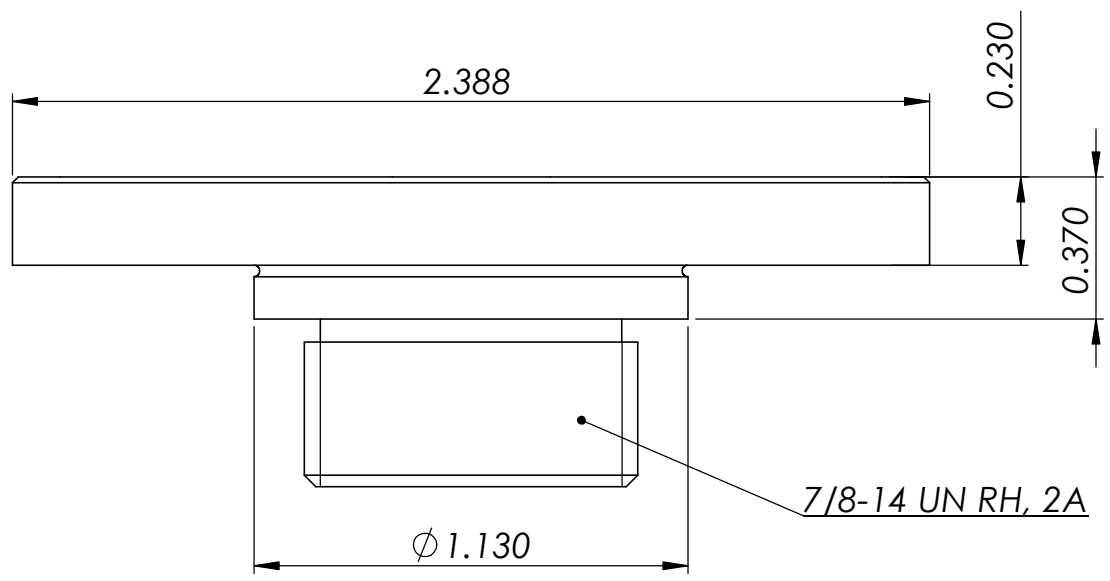
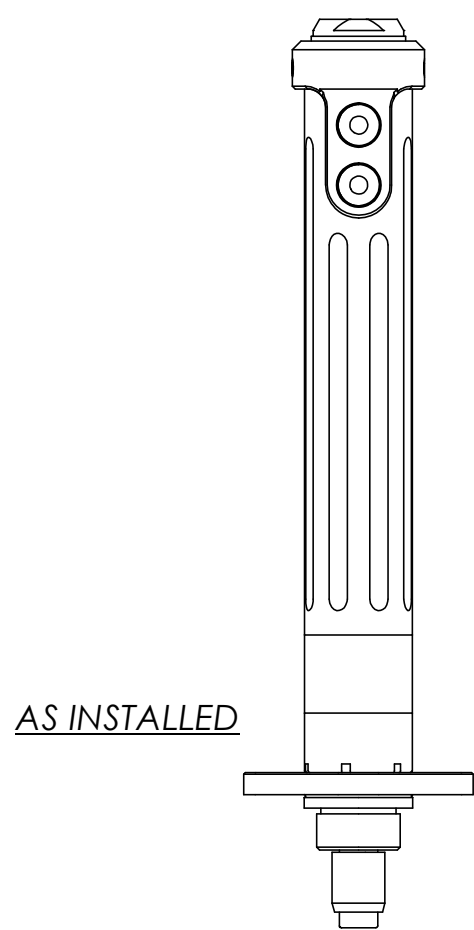

INTENDED FOR USE WITH ASG-SD2500-FX STYLE TOOLS

PROPRIETARY AND CONFIDENTIAL
THE INFORMATION CONTAINED IN THIS DRAWING IS THE SOLE PROPERTY OF ASG A DIVISION OF JERGENS INC. ANY REPRODUCTION IN PART OR AS A WHOLE WITHOUT THE WRITTEN PERMISSION OF ASG A DIVISION OF JERGENS INC. IS PROHIBITED.

UNLESS OTHERWISE SPECIFIED:		NAME	DATE	TITLE: ASG-AC2500-MPJR	
DIMENSIONS ARE IN INCHES		DRAWN			
TWO PLACE DECIMAL ±0.01		CHECKED			
THREE PLACE DECIMAL ±0.005		ENG APPR.			
FRACTIONAL ±1/64		MFG APPR.			
ANGULAR: ± 1/2 DEG		Q.A.		SIZE B DWG. NO. ASG-AC2500-MPJR REV C	
FINISHES 125 MAX		COMMENTS:		WEIGHT: 0.04 SHEET 1 OF 1	
REMOVE ALL BURRS AND BREAK SHARP EDGES 0.005/0.010					
MATERIAL	2024 ALUMINUM				
FINISH					
NEXT ASSY	USED ON				
APPLICATION		DO NOT SCALE DRAWING			

8 7 6 5 4 3 2 1